

LR 2512

Metal Alloy Low-Resistance Resistor



■ Features

- Ideal for all types of current sensing, voltage division and Pulse applications including switching and linear power Supplies, Instruments, power amplifiers.
- Proprietary processing technique produces extremely low Resistance values.
- High-temperature performance (up to +170 °C)
- Metal Strip resistive material stable and ultra low TCR. Low and Stable $TCR \leq \pm 50 \text{ppm}/^\circ\text{C}$
- Pure tin plating provides compatibility with lead (Pb) free and lead containing soldering processes.
- Compatible with "Restriction of the use of Hazardous Substances" (RoHS) directive 2002/95/EC (issue 2004).
- PFOS, PFOA, PAHs, Halogen free and REACH compliant.
- Excellent stability ($|\Delta R/R| \leq \pm 1.0\%$ for 1,000 h at 70 °C) different environment conditions.
- High volume product suitable for commercial and special applications.
- Suitable for high precision current sensing circuit protection application.
- Miniature size suitable for compact Print Circuit Boards of high-precision electronic products.

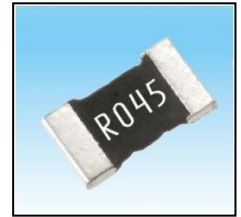

■ Applications

- Power Supply, Battery Pack, DIY Tools, Inverter/Converter(AC/DC, DC/DC, DC/AC)
- Measurable Instrument, Consumer Electrics, Note Book, PC Power Pack, LED Driver
- Others (Auto Tronics...etc.).

■ CHARACTERISTICS

Short Time Overload	$(R/R1) \leq \pm 0.5\%$	1W,1.5W,2W : 5times rated power, 5sec. 3W : 3times rated power, 5sec.
Insulation Resistance	$\geq 10^9 \Omega$	DC100±15V for 1minute
Dielectric Withstanding Voltage	Without break down	AC500V for 1minute, Max.50mA
Resistance to Solder Heat	$(R/R1) \leq \pm 0.5\%$	Solder temp./immersion time : 260±5 °C, 10±1sec. and 350±10 °C, 3.5±0.5 sec.
Solderability test	95% coverage	Specimen prep. : 4hours ±15 min. Steam Aging : Solder Bath/Dip and Look Test, 245±5 °C, 3±1sec.
Vibration	$(R/R1) \leq \pm 0.5\%$	Frequency varied 55Hz in one minute,3 orientations, Total duration 12hours
Resistance to solvent	$(R/R1) \leq \pm 0.5\%$	Immersion time : 60±5sec, 20 °C ~ 25 °C
Mechanical Shock	$(R/R1) \leq \pm 0.5\%$	100 grams for 6 milliseconds, 5 pulses
Low Temperature Exposure(Storage)	$(R/R1) \leq \pm 0.5\%$	1,000hours, -55 °C
High Temperature Exposure(Storage)	$(R/R1) \leq \pm 1.0\%$	1,000hours, +170 °C
Temperature Cycling (Rapid Temp. Change)	$(R/R1) \leq \pm 0.5\%$	Air to air, -55 °C to +150 °C, 1,000cycles, 15minutes at each extreme, transition time 2 to 3 minutes
Moisture Resistance (Climatic Sequence)	$(R/R1) \leq \pm 0.5\%$	Mil-STD-202, Method 106 0% power, 7a and 7b not required, t=24 h/cycle, 10cycles, Unpowered
Bias Humidity	$(R/R1) \leq \pm 0.5\%$	+85 °C, 85% RH, 10% Bias, Extended Life 1000 hours, 1.5 hours On, 0.5 hours Off
Load Life	$(R/R1) \leq \pm 1.0\%$	Rated continuous working voltage : 70 °C 1000hours, 1.5hours ON, 0.5hours Off

GENERAL SPECIFICATIONS

Model	Power Rating at 70°C [Watts]	Max. Rating Current	Max. Overload Current	Operating Temp. Range	TCR [PPM/°C]	Resistance Range[mΩ]**	
						±0.5%(D)	±1.0%(F) ±2.0%(G) ±5.0%(J)
LR2512	1W	44.72A	100.00A	-55 ~ +170°C	0.5~3m=±50 3.1~6.9=±25 7~100m=±15	7.0~100	0.5~100
	1.5W	54.77A	122.48A				
	2W	63.25A	141.42A		0.5~3m=±50 3.1~6.9=±25 7~75m=±15	7.0~75.0	0.5~75.0
	3W	77.46A	134.16A		0.5~2.5m=±50 2.6~10m=±25	7.0~10.0	0.5~10.0

- Remark :
- a. The Max. Power Rating is operated at 70°C.
 - b. **Special tolerance and range of resistance are under requested.
 - c. Rating Current : $I = \sqrt{P/R}$

DIMENSIONS

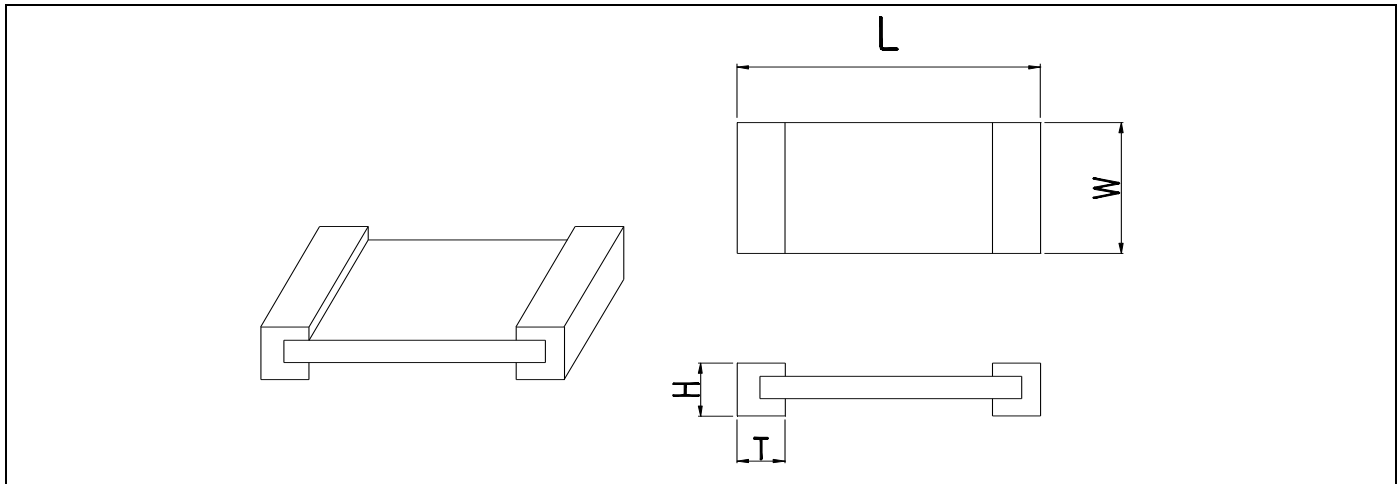

Model	DIMENSIONS - in inches (millimetres)						
	Maximum Power Rating[W]	Resistance Range[mΩ]	L	W	H	T	
LR2512	1.0 & 1.5	0.5~4.0	0.246±0.010 (6.248±0.254)	0.130±0.010 (3.302±0.254)	0.031±0.010 (0.787±0.254)	0.074±0.010 (1.880±0.254)	
		4.1~75.0			0.0254±0.010 (0.645±0.254)	0.044±0.010 (1.118±0.254)	
		75.1~100.0			0.0254±0.010 (0.645±0.254)	0.034±0.010 (0.868±0.254)	
	2.0	0.5~4.0			0.031±0.010 (0.787±0.254)	0.074±0.010 (1.880±0.254)	
		4.1~75.0			0.0254±0.010 (0.645±0.254)	0.044±0.010 (1.118±0.254)	
	3.0	0.5			0.031±0.010 (0.787±0.254)	0.074±0.010 (1.880±0.254)	
		0.6~2.9& 4.1~10.0					0.044±0.010 (1.118±0.254)
		3.0~4.0					0.066±0.010 (1.676±0.254)

ORDERING PROCEDURE EXAMPLE

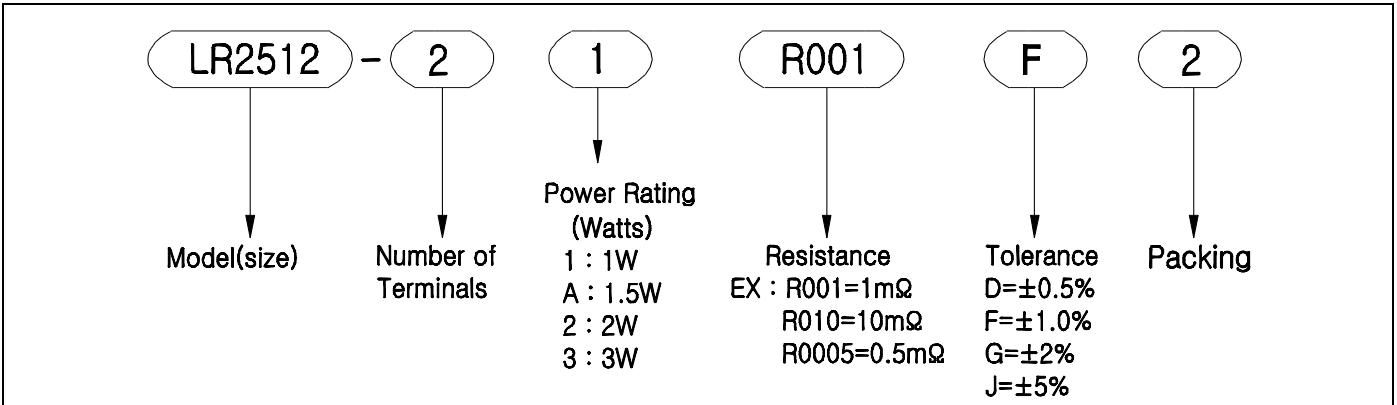

Remark

- a. "*" normal product order information has 4digits, if includes one decimal point then the order information should be 5 digits(e.g. 0.5mΩ is R0005), if includes 2 decimal points, then it should be 6digits (e.g. 0.25mΩ is R00025).
- b. The detail marking format please refer to "MARKING"
- c. "***" special tolerance and range of resistance are under requested.
- d. "***" the packing quantity : 2 means 2k pieces per reel.

MARKING

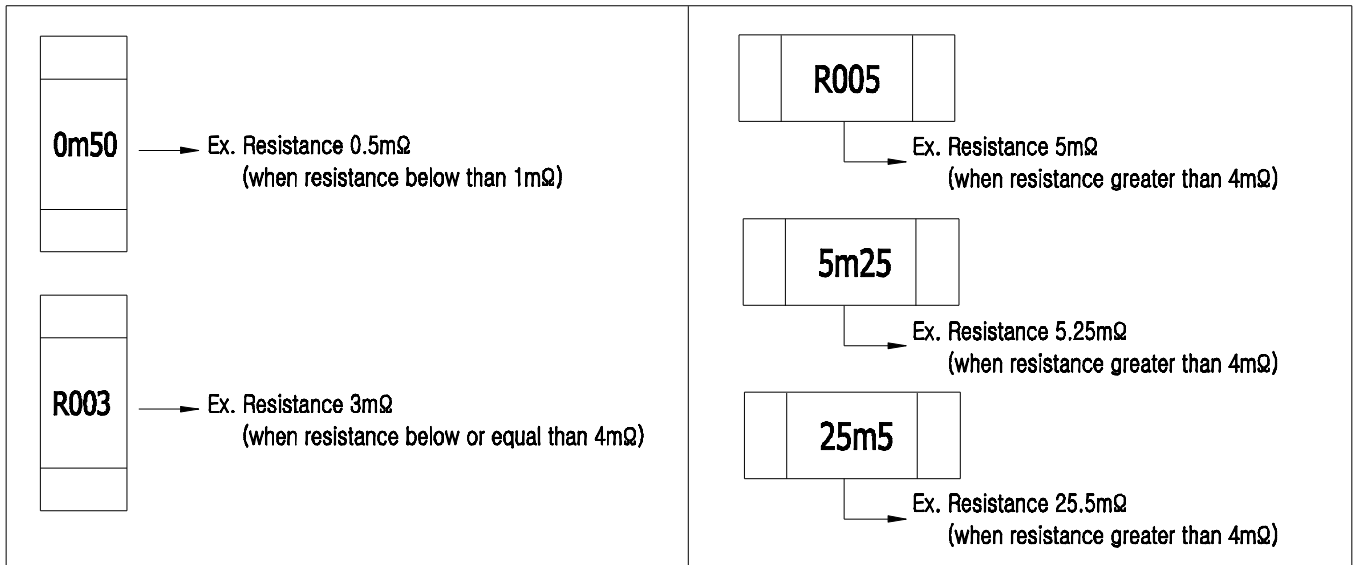

DERATING CURVE

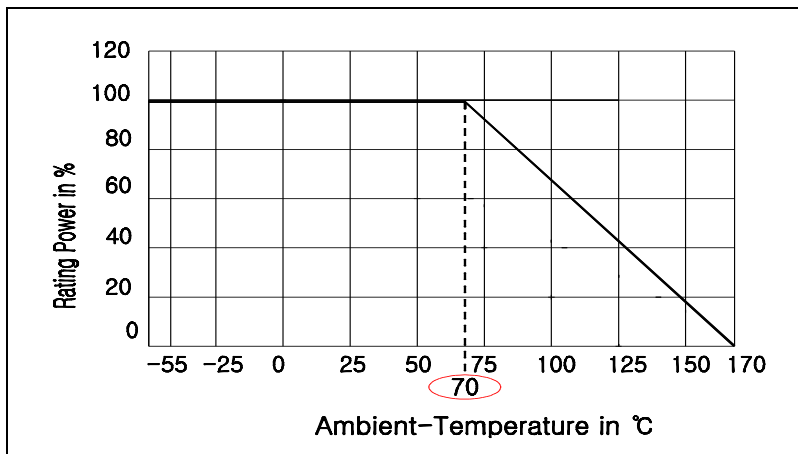

■ SOLDER PAD DIMENSIONS

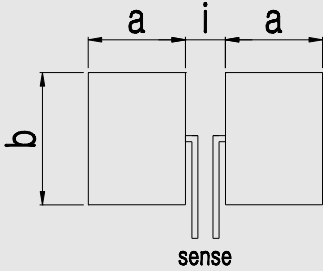

Maximum Power Rating [W]	SOLDER PAD Dimension - in inches (millimetres)			
	Resistance Range [mΩ]	a	b	i
1.0 & 1.5	0.5~4.0	0.120(3.05)	0.145(3.68)	0.050(1.27)
	4.1~100.0	0.083(2.11)	0.145(3.68)	0.125(3.18)
2.0	0.5~4.0	0.120(3.05)	0.145(3.68)	0.050(1.27)
	4.1~75.0	0.083(2.11)	0.145(3.68)	0.125(3.18)
3.0	0.5~1.5	0.120(3.05)	0.145(3.68)	0.050(1.27)
	1.6~10.0	0.083(2.11)	0.145(3.68)	0.125(3.18)

Remark : The total solder pad trace size are recommended as follows.
 1.0W : 100 mm² / 1.5W : 200 mm² / 2.0W : 300 mm² / 3.0W : 400 mm²

■ PACKAGING

▪ Embossed Dimensions

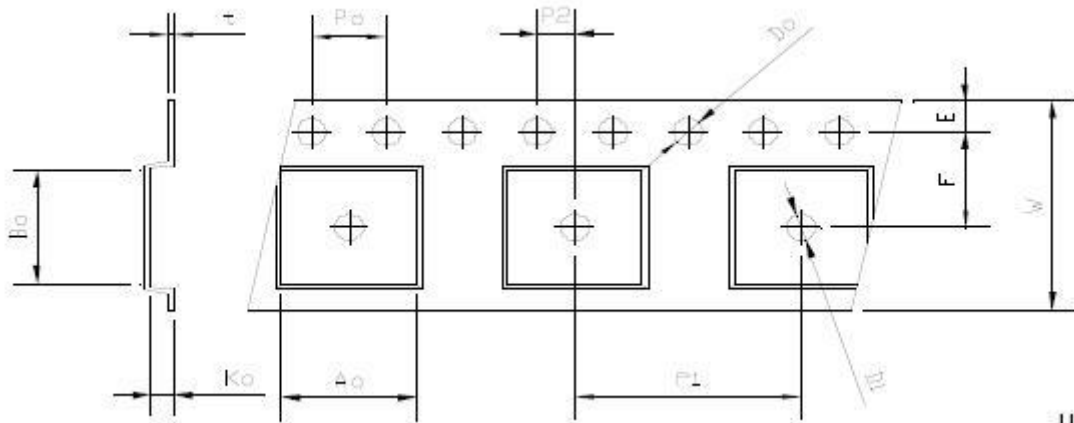

Unit: mm

Item	W	P1	E	F	Do	D1	P0	Po*10	P2	Ao	Bo	Ko	t
Spec.	12.00	8.00	1.75	5.50	1.55	1.50	4.00	40.00	2.00	3.90	6.74	1.08	0.24
Tole.	±0.15	±0.10	±0.10	±0.10	±0.05	±0.10	±0.10	±0.20	±0.10	±0.10	±0.10	±0.10	±0.05

▪ Reel Dimensions (Unit : mm)

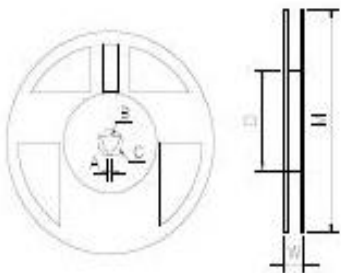

Reel Type / Tape	W	M	A	B	C	D
7" reel for 12mm embossed	16.2±0.5	178±1.0	2.5±0.5	13.5±0.5	17.7±0.5	60.0±0.5